

自動沖床機

AUTOMATIC STRIP FEED PRESS

S-B18G(5) 自動沖床機適用範圍極廣，不僅適用於兩片罐身生產，亦可用於五加侖罐蓋沖製。堆疊之長條鐵皮經由油壓缸上推（亦可連接自動送料機S-B18-2），再由吸盤將鐵皮一片一片送入送料台。送料台內往復運動之送料推桿配合沖頭時序將鐵皮推入沖模內，沖壓成型之罐身（或罐蓋）經由高壓空氣自後方排出而鐵皮廢料經由壓輪自側向排出。沖模由特殊合金鋼製成，堅固耐用。自動潤滑幫浦及多重安全設計，使維修保養容易且操作安全。

S-B18G(5) Automatic Strip Feed Press is built not only for two piece can drawing but also for five gallon end stamping. Piled strips are lifted by a hydraulic cylinder then suck pads send strip one by one to strip feeding station. (Also can link with Automatic Strip Feeder S-B18-2). Reciprocating feeding bar at feeding station send strip into punch tooling. Formed can body or end is ejected out via air blowing to rear while strip scrap is ejected out by a pressing roller to side. Punch tooling is made of alloy steel; hence, sturdy for long life. An automatic greasing pump and multiple safety devices are equipped for easy maintenance and safe operation.

S-B18G(5)

Certified by

ISO-9001

Quality Assurance System

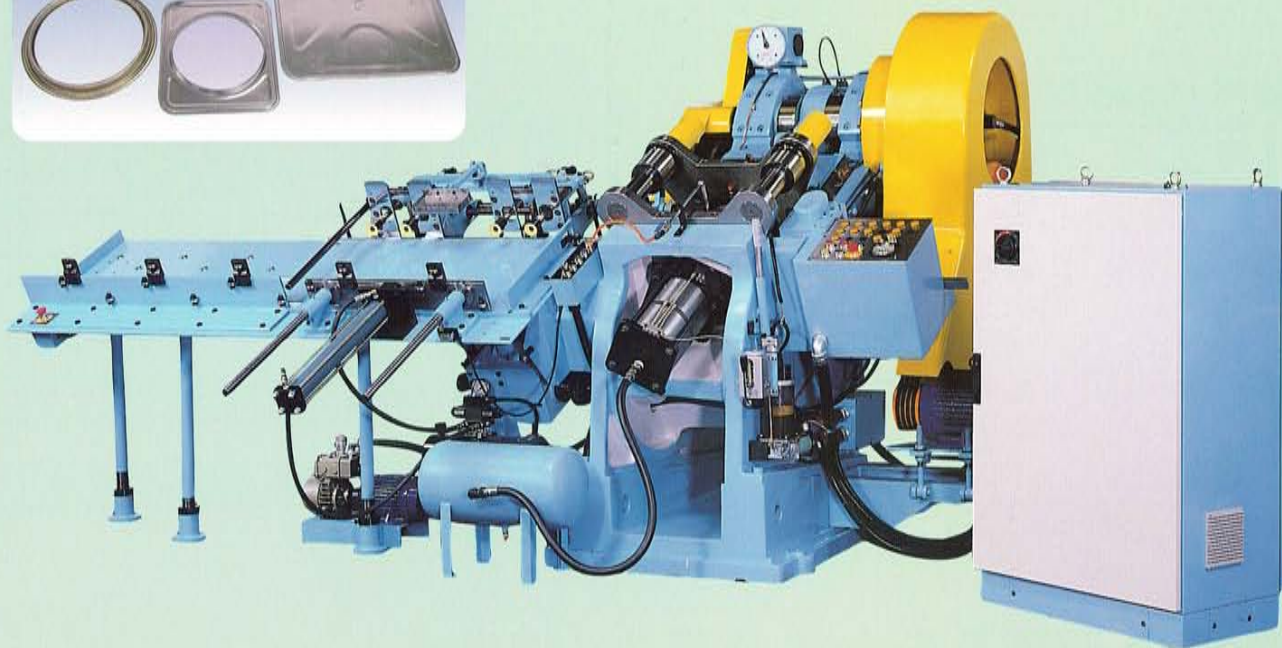

Shin-I
新益

新益機械工廠股份有限公司
SHIN-I MACHINERY WORKS CO., LTD.

自動沖床機

AUTOMATIC STRIP FEED PRESS

特點：

- 沖蓋料片用油壓缸推送，並以近接開關控制料片之高度，確保吸料順利。
- 沖床之啓起動採雙手起動方式，符合安全規定，確保操作安全。
- 使用大型空氣離合煞車器，動力傳送確實穩定。
- 安全設計完善，確保機台及人員安全。
- 換型容易快速，節省時間。
- 可與自動送料機S-B18-2連結使用，節省人力。

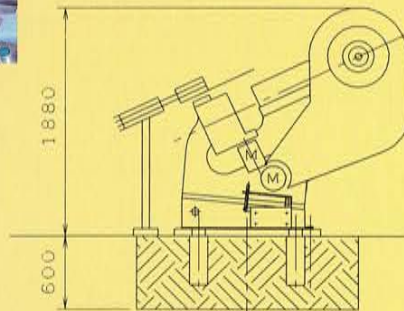
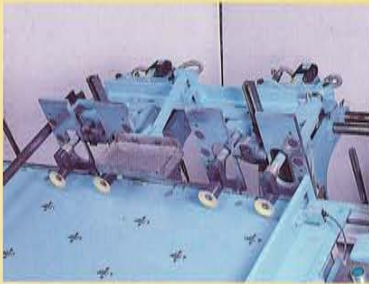

FEATURES:

- Strip lifting by hydraulic cylinder and use proximity switch for strips height control.
- With duplex switch for machine starting, safe and reliable.
- With air clutch for power transmission, effective but low maintenance.
- Multi-safety desing for machine and personnel safety.
- Easy for can size changeover and adjust.
- Can link with auto strip feeder S-B-18-2 for labor cost saving.

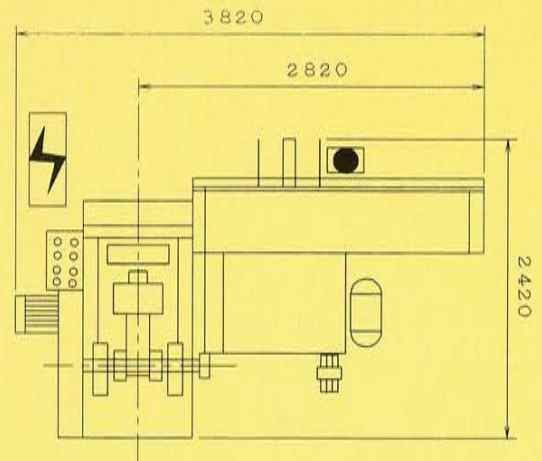

規格 (Specification):

機 型	MACHINE TYPE	S-B18G	S-B18G5
適用罐蓋直徑	Range of end(or can) dia.	211~401 D x 56 mm H	5 GAL End
每分鐘產能	Capacity per minute	Up to 100 CPM	Up to 60 EPM
需要馬力	Horse power required	10HP x 1, 1HP x 1, 1/4 HP x 2	
需要壓縮空氣	Compressed air required	120L/min. x 5Kg/cm ²	
適用鐵皮長度	Range of strip length	510~950 mmL	
適用鐵皮寬度	Range of strip with	128~260 mmW	
淨 重	Net weight (approx.)	5200 Kgs	
安裝面積及高度	Floor space overall height	3610Lx 2500W x 1850H mm	3810L x 2500W x 1850H mm

* 規格如有變動，恕不另通知。 Subject to chang without notice.

新益機械工廠股份有限公司
SHIN-I MACHINERY WORKS CO., LTD.

台灣省台中縣清水鎮清水里中正街43號
NO.43 CHUNG-CHENG STREET, CHING SHUI, TAICHUNG, TAIWAN.
TEL:886-(04)2623-8181 FAX:886-(04)2623-2129

Web address: <http://www.shinican.com>

E-mail: shinican@ms15.hinet.net

經銷商：
AGENT：