

# 自動二片罐身拉製機

## AUTOMATIC STRIP FEED PRESS

(for draw-reverse draw can bodies)

本機是製造罐高較低之圓罐或橢圓罐等二片罐身之自動製罐機械307D × 113H(銷二號)罐以下罐型使用以本廠 S-B26L 自動波型剪鐵機沖剪之料片，採用兩個拉罐模，每分鐘可製造200個罐身。如果比其稍大罐型，如到橢圓一號罐時可改為單一拉罐模亦可造出100個罐身。將料片堆積於供料架，並推移到供料位置後，自料片推升、吸取、輸送到拉罐位置，一直到沖剪罐料、拉製罐身、將罐身以噴氣排出沖床外，並將沖剪出罐料後之廢邊料(Scrap)由沖床射出等之，全部過程，連續自動完成。拉罐模設計週詳，沖床製造精密，故成品規格劃一，罐身光滑優美。

S-B 18GL is an automatic machine specially designed for drawing 2-piece can in round or oval shape. For cans smaller than 307Dx113H or similar, by using a double-die set, S-B18GL can run 200 cans per minute. For large can, single die will be adopted and runs at 100 strokes per minute. With our newly designed "draw reverse draw" die set, S-B18GL is excellent for making cans from double reduced tinplate or tin free steel. Carbide (or ceramic) material is used for drawing in the die to allow the best smooth drawing of can bodies and ensure the machine for 24 hours operation.

Certified by  
**ISO-9001**  
Quality Assurance System

# S-B18GL



**Shin I**  
新益

新益機械工廠股份有限公司  
SHIN I MACHINERY WORKS CO., LTD.

# 自動二片罐身拉製機

## AUTOMATIC STRIP FEED PRESS

(for draw-reverse draw can bodies)

### 優點：

- 由於採用雙模型，減少廢邊料(Scrap)並提高生產。
- 沖床之動力傳達使用空氣離合剎車式，運轉穩定，傳動確實。
- 供料架移動輕便，料片中斷時間短少，不影響製罐作業。
- 料片使用油壓缸推升並以電眼控制，自動保持一定高度，保證吸料順利。
- 上、下拉罐模均附裝氮氣緩衝器，在拉製罐身時壓力平穩，成品形狀整齊、罐身不起皺紋、表面平坦美觀。
- 設噴氣式排罐裝置，向罐身輸送機排出罐身，運送迅速避免出罐阻塞或罐身滯留等所引起之重沖而導致損壞沖模。
- 製造過程中處處設置安全措施，如在輸送料片途中有兩檢出器，送料棒之送料連桿中有過載脫離機構等確保作業安全。
- 重要潤滑部位採用自動潤滑器集中給油。
- 各部門之調整操作容易，換型工作簡單方便。

### Features:

- Air clutch is adopted to ensure effective transmission.
- Basic double die design for save of tinplate material.
- Air cylinders are adopted for buffering the movement of big ram, hence precise stamp can be achieved.
- N<sub>2</sub> cylinders are used for top & bottom die cushion to ensure a very smooth drawing of can bodies.
- Centralized lubrication system ensure the smooth running of the machine.
- Double sheet detectors are used to protect the damage of machine & dies.

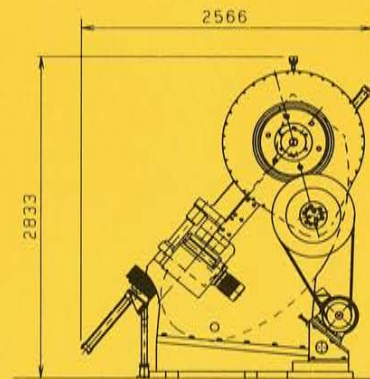
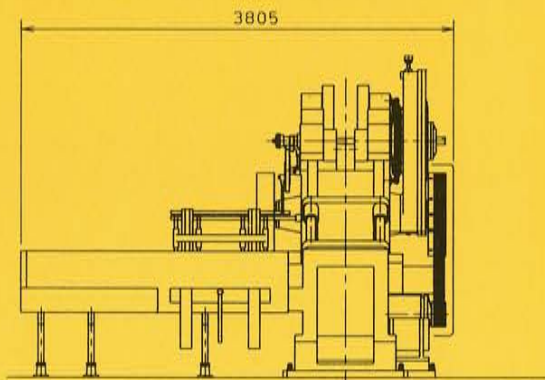

### 規格：SPECIFICATIONS:

適用罐徑	Range of can diameter	round 55—86 mm (for double die setting)
適用罐高	Maximum can height	56mm
適用料片長度	Range of strip length	550—1050mm
適用料片寬度	Range of strip width	200—300mm
每塊料片罐量	Cans per strip	8—16 cans
每分鐘行程數	Stroke per minute	80—100
行程	Length of stroke	200mm
閉合工作高度	Maximum die height	420mm
滑塊調整量	Maximum ram adjustment	60mm
中鋸底面尺寸	Ram bottom area	460×360mm
工作台尺寸	Bolster area	770×480mm
主馬達	Main motor	20 HP
油壓馬達	Hydraulic pump motor	2 HP
真空馬達	Vacuum pump motor	1/2 HP
廢邊料射出器馬達	Scrap ejector motor	1/4 motor
空氣壓縮馬達	Air compressor motor	10 HP
安裝面積及高度	Floor space overall height	3805×2566×2833mm
淨重	Net weight (approximately)	11500 kgs

如有變更，不另通知。

Subject to change, without notice.

**Web address:** <http://shinican.com.tw>

**E-mail:** [shinican@ms15.hinet.net](mailto:shinican@ms15.hinet.net)

**新益機械工廠股份有限公司**

台灣省台中縣清水鎮光華路2號

**SHIN I MACHINERY WORKS CO., LTD.**

NO.2 KUANG HWA ROAD CHING-SHUI TAICHUNG,

TAIWAN, R. O. C.

TEL:(04) 622-4166

FAX:(04) 623-2129

TELEX: 51240 SHINI

**TEL:886-(04)-2623-8181**

**FAX:886-(04)-2623-2129**

經銷商：

AGENT: